

Sensor clamps for microcylinders with threaded end covers and Technopolymer

Sensor clamps - codes 1500._, RS._, HS._	Sensor clamps - codes 1580._, MRS._, MHS._
Ordering code	Ordering code
1260.Ø.F	1260.Ø.FS

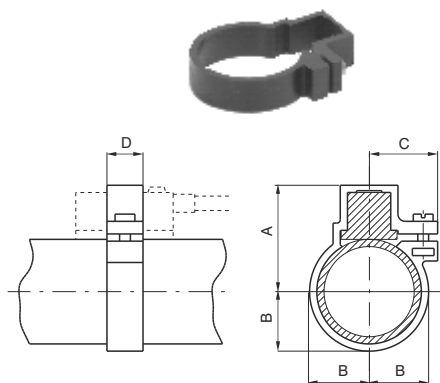

Table of dimensions

Bore	Ø10	Ø12	Ø16	Ø20	Ø25	Ø32	Ø40	Ø50
A	23	23	25	27	29,5	33	37	42
B	10	10	12	14	16,5	20	24	29
C	15	15	16,5	17,5	19	20	22	24
D	10	10	10	10	10	10	10	10
Weight (gr)	2	2	3	5	7	10	14	16

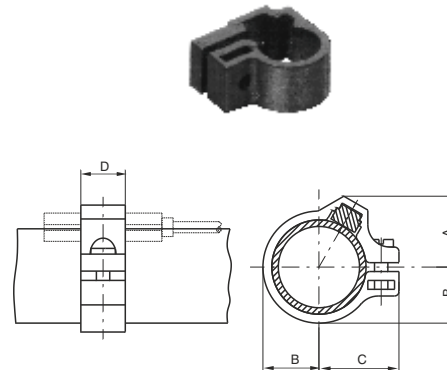

Table of dimensions

Bore	Ø10	Ø12	Ø16	Ø20	Ø25	Ø32	Ø40	Ø50
A	13	14	15,4	17,2	19,3	20,5	22	29
B	9	10	12	14	16,5	20	24	29
C	16	16	18	19,5	22	26	30	35
D	10	10	10	10	10	10	10	10
Weight (gr)	2	2	3	5	7	8	10	11

Sensor clamps for microcylinders with rolled end covers "MIR" and "MIR-INOX"

Sensor clamps - codes 1500._, RS._, HS._	Sensor clamps - codes 1580._, MRS._, MHS._
Ordering code	Ordering code
1280.Ø.F - cylinders MIR 1280.Ø.FX - cylinders MIR-INOX	1280.Ø.FS - cylinders MIR 1280.Ø.FSX - cylinders MIR-INOX

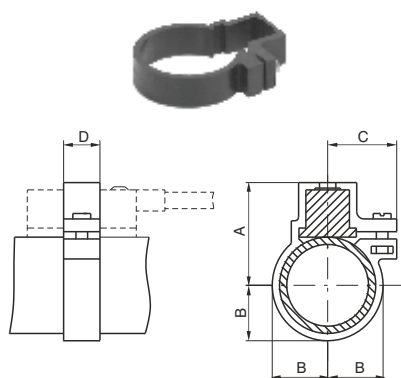

Table of dimensions

Bore	Ø16	Ø20	Ø25	Ø32
A	24	25,5	28,5	31,8
B	10,5	12,5	15,5	18,8
C	16,5	17,5	19	20
D	10	10	10	10
Weight (gr)	3	5	7	10

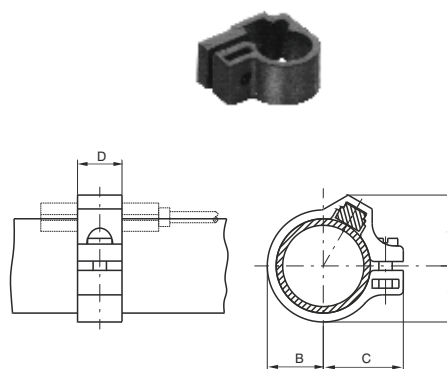

Table of dimensions

Bore	Ø8	Ø10	Ø12	Ø16	Ø20	Ø25	Ø32
A	11	12	13	14,5	16	17,5	19,5
B	6,5	7,5	8,5	10,5	12,5	15,3	18,8
C	12,5	13,5	15	16	18	20,5	24
D	10	10	10	10	10	10	10
Weight (gr)	2	2	2	3	5	7	10

Sensor for microcylinders

For technical characteristics and ordering codes see Chapter 6 (magnetic sensors)

Foot

Ordering code
1200.0.01 (1 piece)

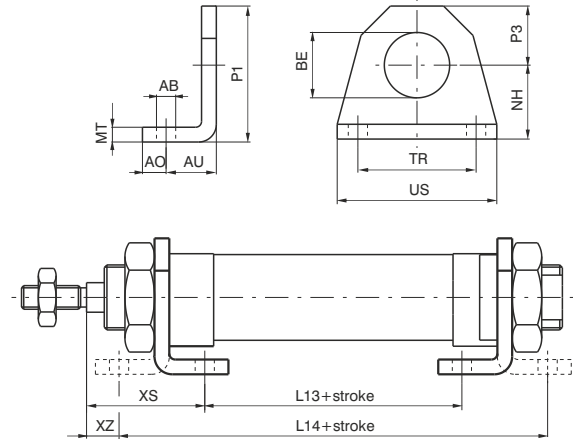

Used to mount the cylinder on the mounting plane with the rod parallel to said plane. Use one for short strokes and two for long strokes. It is made of stamped steel, made corrosion resistant by cataphoresis treatment. Attached to the end plates by means of nuts (or lock nuts) 05.

Attention: the dimensions of microcylinders with threaded end covers (★) increase of 10 mm. for microcylinders equipped with magnetic piston and spring return, and of 9 mm. for microcylinders with 10 mm. BORE magnetic piston.

Bore	8	10	12	16	20	25	32	40	50
AB (H13)	4,5	4,5	5,5	5,5	6,5	6,5	6,5	8,5	8,5
AO	5	5	6	6	8	8	8	10	10
AU	11	11	14	14	17	17	17	20	20
BE	12	12	16	16	22	22	30	40	40
L13 (±1) ★	30	30	30	36	44	45	45	49	52
L14 (±1) ★	68	68	78	84	102	103	103	119	122
MT	3	3	4	4	5	5	5	5	5
NH (±0,3)	16	16	20	20	25	25	28	40	40
P1	26	26	33	33	45	45	50	70	70
P3	10	10	13	13	20	20	22	30	30
TR (JS14)	25	25	32	32	40	40	52	70	70
US	35	35	42	42	54	54	66	90	90
XS (±1,4)	24	24	32	32	36	40	40	50	50
XZ (±1,4)	5	5	8	8	7	11	11	15	15
Weight gr.	22	22	45	45	90	90	110	210	210

Flange

Ordering code
1200.0.02 (1 piece)

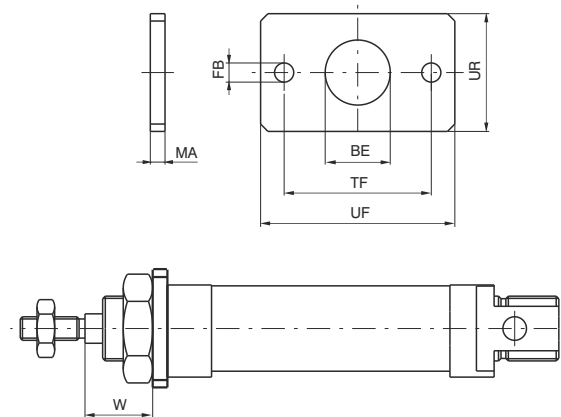
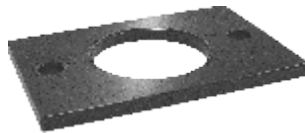

Used to mount the microcylinder at a right angle to the mounting plane. Attached to the front (or rear) endcap by a nut (or lock nut) 05. Made of extruded steel, made corrosion resistant by cataphoresis.

Bore	8	10	12	16	20	25	32	40	50
BE	12	12	16	16	22	22	30	40	40
FB (H13)	4,5	4,5	5,5	5,5	6,5	6,5	6,5	8,5	8,5
UF	40	40	53	53	66	66	68	90	90
UR	25	25	30	30	40	40	50	60	60
MA	3	3	4	4	5	5	5	5	5
TF (JS14)	30	30	40	40	50	50	52	70	70
W (±1,4)	13	13	18	18	19	23	23	30	30
Weight gr.	20	20	40	40	85	85	100	150	150

Rear eye

Ordering code

1200.Ø.03
(1 piece)

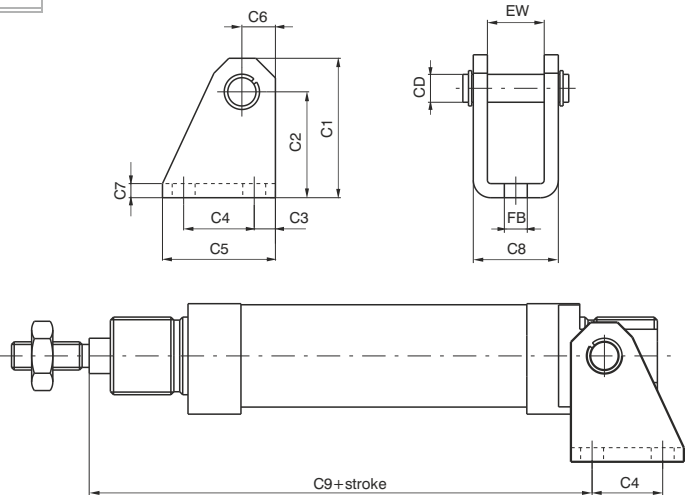

Use with the rear end cover to mount the cylinder either parallel or at a right-angle to the mounting plane. This allows the cylinder to oscillate and self-align with the linked element to the rod. This is necessary when the rod may be subject to lateral during travel.

Attention: the dimensions of microcylinders with threaded end covers (*) increase by 10mm for equipped with magnetic piston and spring return, and by 9mm for microcylinders with 10mm BORE magnetic piston.

Bore	8	10	12	16	20	25	32	40	50
CD	4	4	6	6	8	8	12	14	14
C1	28,5	28,5	33,5	33,5	39,5	39,5	44,5	53,5	53,5
C2 (±0,3)	24	24	27	27	30	30	33	40	40
C3	3,5	3,5	5	5	6	6	7	10	10
C4	12,5	12,5	15	15	20	20	24	28	28
C5	20	20	25	25	32	32	38	45	45
C6	4,5	4,5	6,5	6,5	9,5	9,5	11,5	13,5	13,5
C7	2,5	2,5	3	3	4	4	4	4	4
C8	13	13	18	18	24	24	34	38	38
C9 (±0,4) *	63	63	73,5	80,5	91,5	100,5	100,5	119,5	122,5
EW	8,1	8,1	12,1	12,1	16,1	16,1	26,1	30,1	30,1
FB (H13)	4,5	4,5	5,5	5,5	6,5	6,5	6,5	8,5	8,5
Weight gr.	20	20	35	35	75	75	135	180	180

Cylinder rod forks / Nut or lock nut for the endcaps

Ordering code

1200.Ø.04 *
(with pin)

1200.Ø.04/1
(with clips)

*Available from bore Ø12

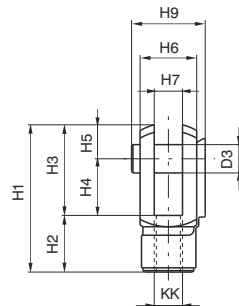
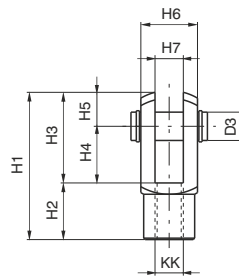
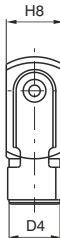
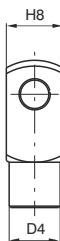

Ordering code

1200.Ø.05

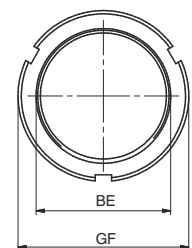
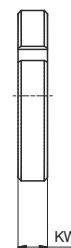
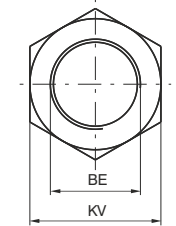
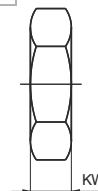
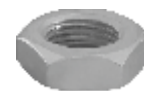

Forks:

Similar to hinge 03, mounted on the rod thread, assures a regular operation even in the presence of significant forces to the linked element. Made of zinc plated steel.

Nut:

Used to fasten flanges or feet to the endcaps of the microcylinder. The nuts are mounted on BORES that go from 8 to 25, the lock nuts on 32, 40 and 50. Both are supplied (one piece) with the microcylinders.

Bore	D3	D4	H1	H2	H3	H4	H5	H6	H7 (B12)	H8	H9	KK	BE	KV	GF	KW	Forks weight gr.	Nut weight gr.
8	4	8	21	8	13	8	5	8	4	10	11	M4x0,7	M12x1,25	17	-	5,5	12	7
10	4	8	21	8	13	8	5	8	4	10	11	M4x0,7	M12x1,25	17	-	5,5	12	7
12	6	10	31	12	19	12	7	12	6	12	18	M6x1	M16x1,5	22	-	6	20	16
16	6	10	31	12	19	12	7	12	6	12	18	M6x1	M16x1,5	22	-	6	20	16
20	8	14	42	16	26	16	10	16	8	16	23	M8x1,25	M22x1,5	30	-	7	45	25
25	10	18	52	20	32	20	12	20	10	20	27	M10x1,25	M22x1,5	30	-	7	90	25
32	10	18	52	20	32	20	12	20	10	20	27	M10x1,25	M30x1,5	-	42	8	90	42
40	12	20	62	24	38	24	14	24	12	24	32	M12x1,75	M40x1,5	-	52	9	145	60
50	12	20	62	24	38	24	14	24	12	24	32	M12x1,75	M40x1,5	-	52	9	145	60

Foot

Ordering code

1200.Ø.01X
(1 piece)



Used to mount the cylinder on the mounting plane with the rod parallel to said plane. Use one for short strokes and two for long strokes. It is made stamped stainless steel AISI 304. Attached to the end plates by means of nuts (or lock nuts) 05X.

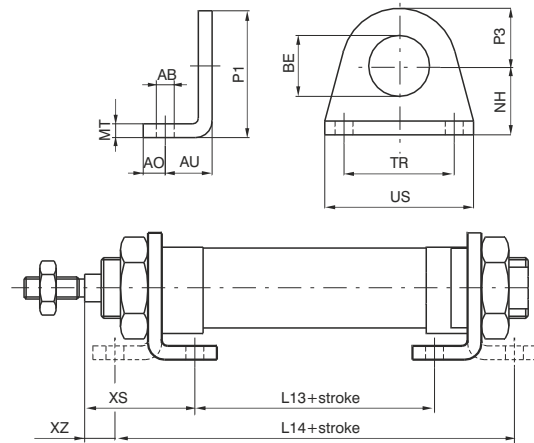

Bore	16	20	25	32
AB (H13)	5,5	6,5	6,5	6,5
AO	6	8	8	8
AU	14	17	17	17
BE	16	22	22	30
L13 (±1)	36	44	44	45
L14 (±1)	84	102	102	103
MT	4	5	5	5
NH (±0,3)	20	25	25	28
P1	33	45	45	50
P3	13	20	20	22
TR (Js14)	32	40	40	52
US	42	54	54	66
XS (±1,4)	32	36	40	40
XZ (±1,4)	8	7	11	11
Weight gr.	45	90	90	110

Flange

Ordering code

1200.Ø.02X



Use to mount the microcylinder at a right angle to the mounting plane. Attached to the front (or rear) endcap by a nut (or lock nut)05X. Made of stainless steel AISI 304.

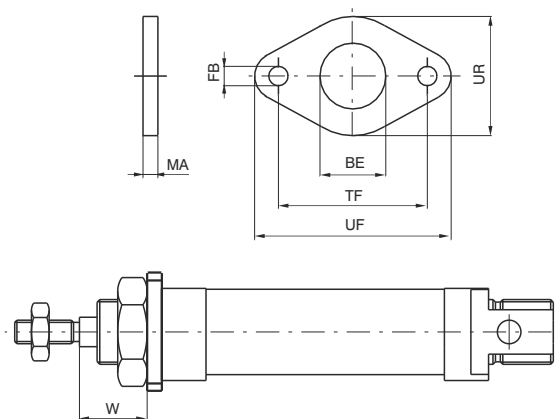

Bore	16	20	25	32
BE	16	22	22	30
FB (H13)	5,5	6,5	6,5	6,5
UF	53	66	66	68
UR	30	40	40	50
MA	4	5	5	5
TF (JS14)	40	50	50	52
W (±1,4)	18	19	23	23
Weight gr.	40	85	85	100

Rear eye

Ordering code

1200.Ø.03X
(1 piece)

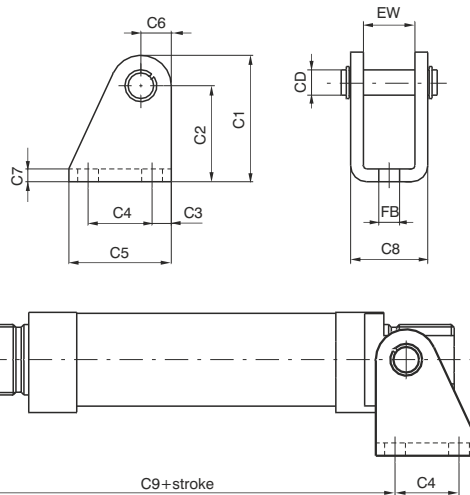

Used to mount by using the rear end cover to mount either parallel or at a right angle to the mounting plane. Allows the cylinder to oscillate and self-align with the linked element to the rod. Necessary to use when the rod may be subject to lateral forces during travel. Made of stamped stainless steel AISI 304.

Bore	16	20	25	32
CD	6	8	8	12
C1	33,5	39,5	39,5	44,5
C2 (±0,3)	27	30	30	33
C3	5	6	6	7
C4	15	20	20	24
C5	25	32	32	38
C6	6,5	9,5	9,5	11,5
C7	3	4	4	4
C8	18	24	24	34
C9 (±0,4)	80,5	91,5	100,5	100,5
EW	12,1	16,1	16,1	26,1
FB (H13)	5,5	6,5	6,5	6,5
Weight gr.	35	75	75	135

Cylinder rod fork / Nut or lock nut for the endcaps

Ordering code

1200.Ø.04X
(with pin)

1200.Ø.05X
(1 piece)

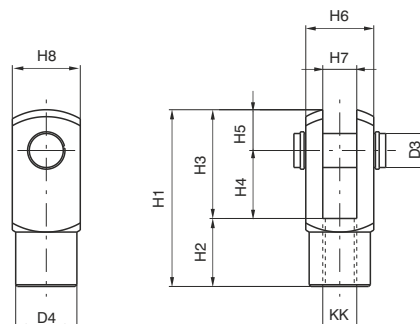

Fork:

Similar to hinge 03X, mounted on the rod thread, assures a regular operation even in the presence of significant forces to the linked element. Made of stainless steel AISI 304.

Nut:

Used to fasten flanges or feet to the endcaps of the microcylinder. The nuts are mounted on BORES that go from 16 to 25, the lock nuts on 32. Both are supplied (one piece) with the microcylinders.

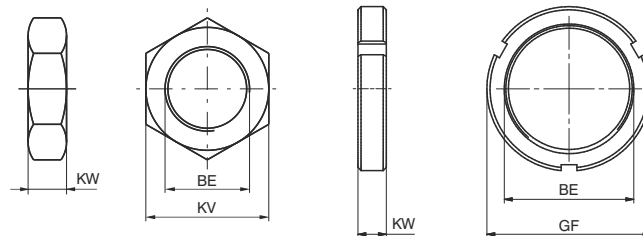

Bore	Weight gr. forks	Weight gr. nut	D3	D4	H1	H2	H3	H4	H5	H6	H7 (B12)	H8	KK	BE	KV	GF	KW
16	20	16	6	10	31	12	19	12	7	12	6	12	M6X1	M16X1.5	22	-	6
20	45	25	8	14	42	16	26	16	10	16	8	16	M8X1.25	M22X1.5	30	-	7
25	90	25	10	18	52	20	32	20	12	20	10	20	M10X1.25	M22X1.5	30	-	7
32	90	42	10	18	52	20	32	20	12	20	10	20	M10X1.25	M30X1.5	-	42	8

Construction characteristics

Body	extruded shape anodized aluminium alloy 6060
Bushings	sintered bronze
Wiper	oil resitant NBR rubber
Rods	chromed C43 steel
Plate	plated zinc steel
Mounting block	plated zinc steel

Technical characteristics

Max. suggested strokes for 1200 series:

Diameter	20	25
Stroke mm	200	250

Max. suggested strokes for 1320 series:

Diameter	32	40	50	63	80
Stroke mm	300	350	450	500	550

Loading diagram based on dimension "A"

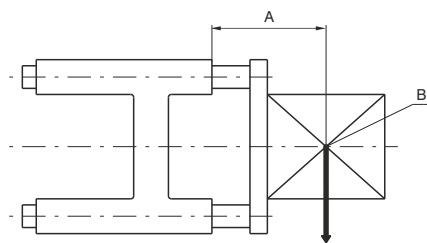

A = Protusion
B = Load centre of gravity

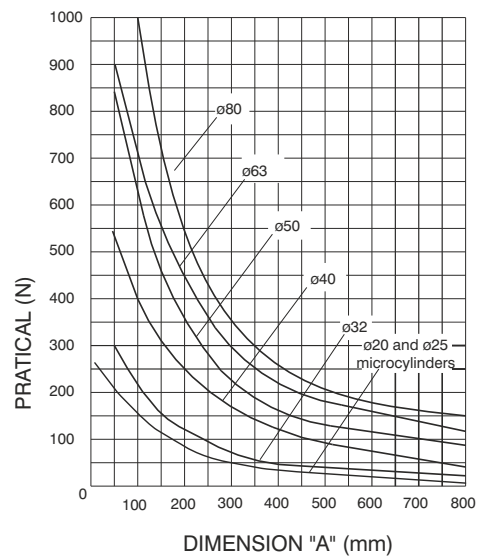

Use and maintenance

Follow the indication of the above diagram as far as loads are concerned. A large quantity of grease is placed between the two wipers during assembly, therefore the linear control units should not require special maintenance.

Microcylinders for piston rod lock

Threaded end covers version

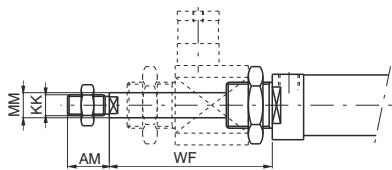

Ordering code

12_ _Ø.stroke.B

Order piston rod lock separately. Do not use with stainless steel or hexagonal piston rod.

Piston rod lock complete

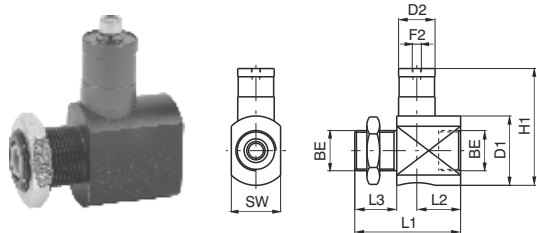

Do not use as safety device

Ordering code

1260.Ø.51BS

Ø	12	16	20	25	32
Weight gr.	82	82	140	140	188

Piston rod lock bracket

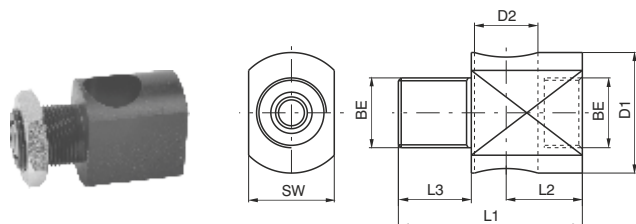

Ordering code

1260.Ø.51S

Ø	12	16	20	25	32
Weight gr.	60	60	85	85	133

Piston rod lock and housing

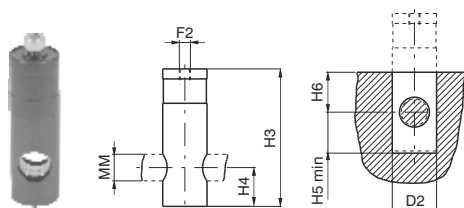

Do not use as safety device

Ordering code

1260.Ø.51B (Ø12-Ø25)

1320.32.51B (Ø32)

Ø	12	16	20	25	32
Weight gr.	22	22	55	55	55

Table of dimensions (series 1200)

Bore	AM	BE	D1	D2	F2	H1	H3	H4	H5	H6	KK	L1	L2	L3	MM	SW	WF
12	16	M16x1.5	20	16	M5	35	35	10	11	10	M6x1	42	21	12	6	20	55
16	16	M16x1.5	20	16	M5	35	35	10	11	10	M6x1	42	21	12	6	20	55
20	20	M22x1.5	38	20	M5	64	62	17.5	19	18	M8x1.25	58	24	23	8	27	73
25	22	M22x1.5	38	20	M5	64	62	17.5	19	18	M10x1.25	58	24	23	10	27	77
32	20	M30x1.5	39.5	20	M5	64	62	17.5	18.5	18	M10x1.25	60	26	22	12	35	76.5